

STD-2

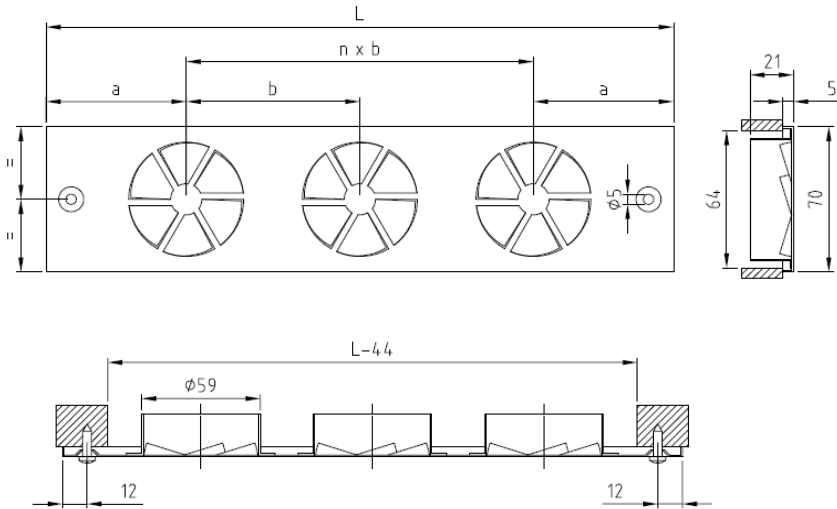

Tip STD-2/2



Tip STD-2/3

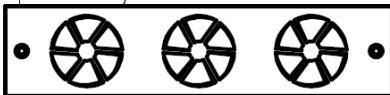

Tip STD-2/4

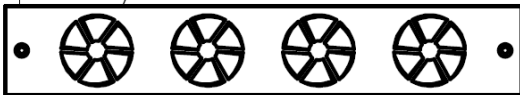

Tip STD-2/5

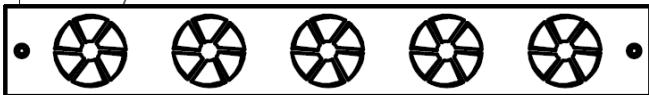

Tip STD-2/6

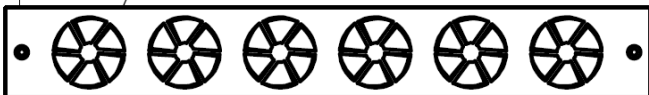

Floor installation

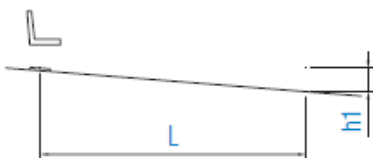

Stair installation

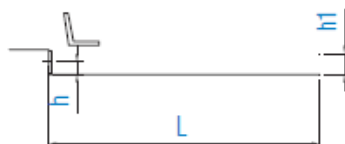

Staircase swirl diffuser STD-2

Application:

Staircase swirl diffusers STD-2 are ideal for use in theatres, auditoria, concert halls, cinemas, etc. They can be installed vertically in steps or floors which do not carry foot traffic. The permitted supply air temperature difference is $\pm 6K$

Description:

STD-2 are made of galvanized sheet steel and powder coated in RAL 9010. On customer's request they are available in any other RAL colour.

Dimensions STD-2...6			
Type	L (mm)	a (mm)	n x b
STD-2/2	200	60	1 x 80
STD-2/3	300	67	2 x 83
STD-2/4	400	68	3 x 88
STD-2/5	500	66	4 x 92
STD-2/6	500	62.5	5 x 75

Installation

- \dot{V} (l/s) Volume flow per diffuser
- \dot{V} (m³/h) Volume flow per diffuser
- H (m) Installation height above floor (min. 50 mm)
- L (m) Distance from diffuser (L=h+x)
- h₁ (m) Height of measurement point above floor
- v_{h1} (m/s) Time average air velocity at height h₁ above floor
- Δt_z (K) Temperature difference between supply air and room air*
- Δt_{h1} (K) Difference between core temperature at height h₁ above floor and room temperature*
- Δp_t (Pa) Total pressure drop
- L_{WA}(dB(A)) A-weighted sound power level

* The room temperature is measured at 1.0 m to 1.3 m above the floor.

Calculation example:

An auditoria with 130 seats is equipped with staircase swirl diffusers STD-2. The amount of supplied air is 1170 l/s, which means $\dot{V} = 9$ l/s per diffuser. The diffuser is fixed vertically into the step.

- Installation height above floor h=0.15m
- Distance from diffuser L=0.7m
- Distance of the measuring point from the floor h₁ 0.15m
- Temperature difference between supply air and room air $\Delta t_z = -3$ K

Diagram 1:

- L_{WA} = 30 dB (A)
- $\Delta p_t = 17$ Pa

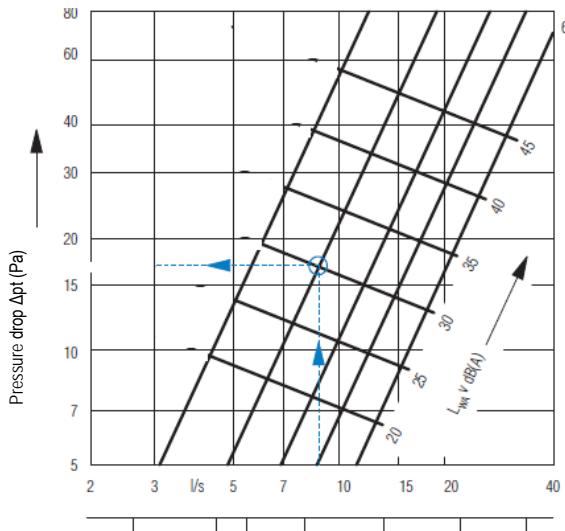
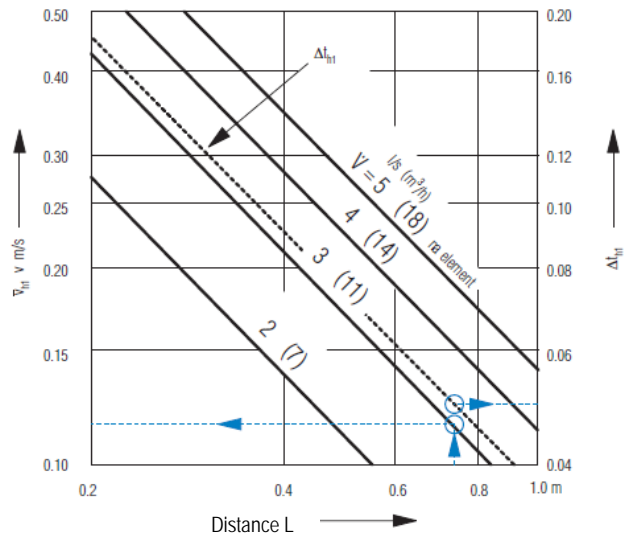

Diagram 2:

- $\bar{v}_{h1} = 0.12 \times 1.73 = 0.21$ m/s
- $\Delta t_{h1} = 0.051 \times 1.73 = 0.088$
- $\Delta t_i = 0.088 \times (-3) = -0.26$ K



Effective discharge area	
No. of elements	A (m ²)
2	0.00126
3	0.00189
4	0.00252
5	0.00315
6	0.00378

Diagram 2: Correction factors					
No. of el.	2	3	4	5	6
$\bar{v}_{h1} \times$	1.41	1.73	2.00	2.24	2.45
$\Delta t_i \times$	1.41	1.73	2.00	2.24	2.45

Ordering key

STD-2/2

- 2 No. of distributive elements
- 3 No. of distributive elements
- 4 No. of distributive elements
- 5 No. of distributive elements
- 6 No. of distributive elements